

## **Investigation for Use of Pin in Paste<sup>®</sup> Reflow Process with Combination of Solder Preforms to Eliminate Wave Soldering**

Guhan Subbarayan, Scott Priore  
Assembly Sciences and Technology, Cisco Systems, Inc.  
San Jose, California  
[gusubbar@cisco.com](mailto:gusubbar@cisco.com)

Paul Koep, Scott Lewin\*, Rahul Raut  
Cookson Electronics - Assembly Materials  
South Plainfield, NJ;  
\*Elgin, IL

Sundar Sethuraman  
Jabil Circuits  
San Jose, California

### **ABSTRACT**

The Pin in Paste (PiP) technology is the process of soldering Pin through hole (PTH) components using the Surface Mount Technology (SMT) reflow process. The use of PiP process offers several advantages compared to the traditional wave soldering process. One of the primary advantages is lowering of cost due to the elimination of the wave soldering process and its associated tooling cost and potential handling damage. Another advantage is that with the wave soldering process, it is extremely difficult to achieve adequate holefill on thermally challenging thick Printed Circuit Boards (PCBs). However, by using PiP process with combination of solder preforms, it is possible to achieve adequate holefill and reliable solder joints for soldering PTH components.

The objective of this study is to investigate the use and limitations of machine-placed solid solder preforms during the top-side SMT reflow process for PTH components. An experiment was designed to investigate the following problems:

- 1) How much additional volume is provided by the combination of printed solder paste plus preforms in determining final barrel fill volume?
- 2) How far away from the hole can the paste and preform extend and still coalesce during reflow?
- 3) What is the optimum lead to hole ratio for the use of solder preforms?
- 4) What is the effect of pin protrusion on the PiP process?
- 5) What are the limitations in placing preforms within printed solder paste?
- 6) What are the design considerations required for the different / various PTH components to be suitable for the PiP process with solder preforms?
- 7) What is the effect of different types of solder masks on the PiP process?

The experiment was conducted on a 130 mil test vehicle using both tin-lead and lead-free materials and processes. The results of this designed experiment along with the inspection methods are presented and discussed in detail in this paper. The outcome of this study will thus provide process engineers extensive guidelines for implementing PiP technology with combination of solder preforms.

### **1. INTRODUCTION AND BACKGROUND**

Most of the components that are used today in electronics industry are available as Surface Mount Technology (SMT) components. However, there are still a quite large number of components, especially connectors, that have through hole leads, mainly for the purpose of mechanical strength. For soldering these PTH components, wave soldering, has been the most commonly used assembly process so far in the industry. An alternative approach for soldering PTH components, is applying solder paste on the top side of the Printed Circuit Board (PCB) around the annular ring pad, as shown in Figure 1 and reflow soldering the component. This process is known as 'Pin in Paste' (PiP) process and sometimes referred to as intrusive reflow soldering or 'Paste in Hole' (PiH) soldering. The PiP has the following benefits over the traditional wave soldering process:

1. The PiP process has the potential to eliminate the cumbersome wave soldering process step and thus reducing the extra production cost. The PiP process option is very appealing, if a PCB has mostly SMT components and a very few PTH components.
2. In a PiP process, the PCBAs are exposed to one less thermal cycle in the assembly process. This removes the potential for PCB degradation due to additional thermal excursions.
3. In wave soldering, if the PCB design contains connections to internal ground or power planes, the heat rising from the bottom is dissipated into the planes and acts as an internal heat-sink, not allowing the top of the barrel to reach the melting temperature of the solder. Thus, the rising column of molten solder will stop its wetting action at the plane of contact, resulting in insufficient barrel fill. In a PiP process, the barrel fill is independent of plane connections, as the solder fills the barrel from the top of the PCB by action of gravity and relies on the heat of the SMT process.
4. In wave soldering, the heating of the board is the result of the contact with the solder wave, so a significant temperature gradient is present, with the top side of the board always at a lower temperature than the bottom side. Even with additional top side heating, this temperature gradient is never eliminated. Since solder is attracted to heat, the solder flow is reluctant to move to the top side of the board, since it is colder, resulting in incomplete barrel fill. This is not the case in "PiP" soldering.
5. During wave soldering, a significant amount of copper is dissolved by the solder wave coming in contact with knee of the barrel. In PiP process, since the barrel is filled from the topside and the volume of solder exposed to barrel is fixed, there would be no risk of copper dissolution.

The PiP process is not a new technology and had been used in the industry, for the last 10 to 15 years. Several studies had been published on PiP process, both for tin-lead and lead-free assembly [1, 2, 3]. In the traditional PiP process, the barrel is filled only from solder paste volume printed around the annular ring pad. The solder paste consists only of 50% metal by volume and the rest of the 50% of volume is flux. Therefore, only half of the paste volume deposited onto the PCB results in solder that fills the barrel. Many products used for servers and networking application have PCBs that are typically >0.100" thick and have very small components such as 0402 resistors and capacitors; the stencil thickness is therefore limited to a 0.005" thickness. So solder paste alone could not provide enough volume to fill the barrel of PTH components, without the addition of supplemental solder to compensate the difference. The addition of solder preforms can overcome this limitation by providing additional solder volume.

Although solder preforms have been around for a long time, in the form of washers placed around PTH component leads, the installation had been cumbersome and labor-intensive at best. Some automation was later introduced, but it required a significant amount of additional equipment such as bowl feeders to present the washers to the pick and place equipment for automated placement. This type of production environment was suited to extremely high volumes of a single washer size. Without these benefits of scale, the washer solution continued to be limited to hand assembly or the use of vibratory jigs to assist the population of the washers on the pins, still with considerable manual labor involved. A very recent advancement in technology is the availability of solder preforms, in the shape of chip components such as 0402, 0603 and 0805, that could be machine-placed, touching but not blocking the paste deposited over the PTH hole (see figure 2). During reflow, the paste liquefies and the surface tension of the molten solder will "wet" to the preform's surface and draw it into the molten pool, allowing it to melt and homogenize with the liquid solder. As the solder wets the barrel wall and the PTH lead, it flows down the barrel and fills the gaps between the lead and barrel wall. The various types of solder preforms available in the market and their dimensions are listed in Table 1.

**Challenges for implementing PiP process with solder preforms:** Although PiP process with combination of solder preforms is an attractive option to wave soldering, there are some challenges that need to be addressed before the process could be implemented in the production line. The two main challenges are:

- 1) Component temperature: Most of the PTH components available in the market today, are designed for the wave soldering process and cannot withstand the high SMT reflow temperature. For lead-free assembly process, the components must withstand 260 °C for 10 to 20 seconds.
- 2) Component Standoff for preforms: An adequate standoff is required underneath the component body to provide a path for preforms to freely move into the solder paste prior to melting, and the solder to flow into the barrel after it is melted. Without standoffs, the component housing would interfere with the path of preforms when pulled towards the barrel, resulting in solder balls around the component.

To address the above challenges, the Original Equipment Manufacturers (OEMs) have to lead the efforts and drive their component suppliers to design the components compatible for PiP process. Once the components are available for PiP process, the next step would be to optimize the assembly process parameters for successful implementation in production. In this study, an extensive design of experiment (DOE) was conducted to study and optimize major assembly process variables that influence the PiP process with combination of solder preforms.

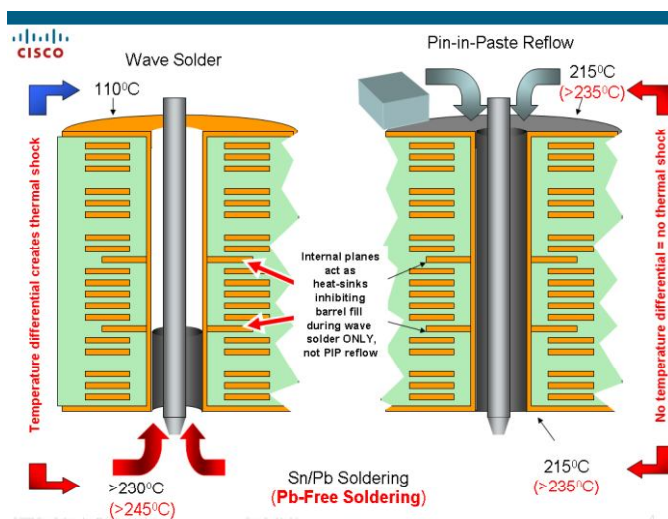

Figure 1: Wave Solder vs. PiP Preform Soldering

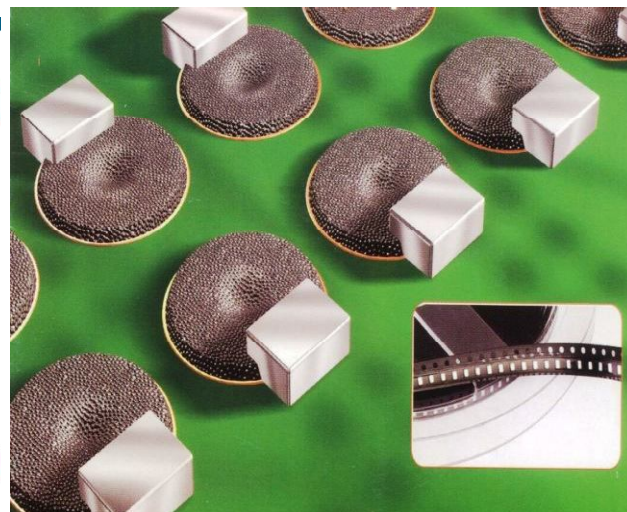

Figure 2: Solder Preforms in Solder Paste

Part type inch	Part type mm	Part dimensions						Volume	
		Length		Width		Height		mm <sup>3</sup>	inch <sup>3</sup>
		mm	inch	mm	inch	mm	inch		
0402H	1060H	1	0.039	0.6	0.02	0.25	0.01	0.15	0.000009
0402	1050	1	0.039	0.5	0.02	0.5	0.02	0.25	0.000015
0402B	1055	1	0.039	0.55	0.022	0.55	0.022	0.3	0.000018
0603H	1608H	1.6	0.063	0.8	0.031	0.5	0.02	0.64	0.000039
0603	1608	1.6	0.063	0.8	0.031	0.8	0.031	1.02	0.000061
0805	2013	2.01	0.079	1.3	0.051	0.76	0.028	1.98	0.000113
1406	3515	3.56	0.14	1.52	0.06	0.77	0.03	4.17	0.000254

Table 1: Solder Preform Types and Dimensions

## 2. EXPERIMENT

### 2.1 HOLEFILL CALCULATION:

The first step when designing for PiP process is to determine the amount of solder required to make an ideal PTH solder joint (100% holefill with a top fillet of height 15 mils). This is expressed by the following equation:

$$\text{Required Solder Volume (RSV)} = \text{Volume required to completely fill the barrel (BV)} + \text{Volume required to make a top fillet of 15 mils (FV)} \quad [1]$$

$$BV = \text{Hole Volume} - \text{Pin Volume} \quad [2]$$

In a PiP process with combination of solder preforms, the amount of solder from provided by two different sources as given in equation 2.

$$RSV = \text{Solder Paste Volume (SPV)} + \text{Preforms Volume(PV)} \quad [3]$$

It should be noted, for the above calculation, that solder paste consists of 50% metal volume and 50% flux, flux activation and binder volume. The solder paste volume is calculated by the following equation:

$$SPV = \text{Solder paste printed on pad (SPV}_{pad}) + \text{Solder paste pushed inside the barrel during printing (SPV}_{Barrel}) \quad [4]$$

$$SPV_{pad} = \text{Area of Print Aperture} \times \text{Stencil Thickness} \quad [5]$$

The volume of solder paste pushed inside the barrel ( $SPV_{\text{Barrel}}$ ) during printing, was found to be linearly proportional to the hole diameter and could be measured quantitatively using a 5DX equipment.

The preforms volume is given by the following equation.

$$\text{Preforms Volume} = \text{Height} \times \text{Width} \times \text{Length} \quad [6]$$

By using the above equations, the following parameters were determined to completely fill the barrel and form a top fillet.

- a) Aperture dimensions of the stencil. This will determine the amount of solder paste deposited on the annular ring pad. Solder paste can be overprinted around an annular ring, provided there is enough real estate around the pad.
- b) Preforms combination: After determining the aperture dimensions, the next step is to determine the preforms combinations, that would be required to provide the remaining solder volume to achieve the RSV (equation 1). An Excel calculator was developed to perform these calculations in a fast and efficient manner.

## 2.2 DESIGN OF EXPERIMENT:

An experiment was designed to study all the important assembly process variables involved in a PiP process with combination of solder preforms. All the problem statements and the variables studied are enumerated in Table 2. The variables were studied independently of each other, changing only one variable, while keeping other variables at the constant, listed in Table 2. For example, while studying the variable pin protrusion, all other variables were kept constant as listed in Table 2.

DOE Purpose	Description of Levels	-2	-1	0	1	2
1. Any difference between tin-lead and lead-free process?		No	#	#	#	Yes
2. Any difference between circular and square annular ring?	Shape of annular ring pad	Square	#	#	#	Circular
3. Any difference between glossy and matte solder mask?		Yes	#	#	#	No
4. How far from the hole can the paste and preform extend and still coalesce during reflow?	Stencil aperture in mils.	150 X 150	175 X 175	200 X 200	225 X 225	250 X 250
5. Print by offsetting and find overprint limit as in problem statement 4	Stencil aperture in mils.	150 X 150	175 X 175	200 X 200	225 X 225	250 X 250
6. Place various size preforms and determine additional volume provided by preforms.	Types of preforms	202	402	603	805	1406
7. What are the limitations of placing preform within the solder paste?	How much % of preforms is lying within solder paste?	100%	75%	50%	25%	15%
8. What is the optimum Lead to Hole Clearance?	(Hole Diameter - Pin Diameter) in mils	10	20	30	40	50
9. What is the effect of pin protrusion on PiP process?	Pin protrusion length in mils	0	25	50	75	100
10. What is the maximum ratio of Preform Volume to Solder Paste volume that will have adequate flux to make a good solder joint?	Block stencil hole?	4		6		9
11. What types of components are suitable for PiP process?	Type of PTH Components	Power Bricks	Headers	RJ45	Caps	Staple Pins

Table 2: Problem Statement and Design of Experiment

Factors	Default Level
Printing position	Center
Pin Protrusion	30 mils
Preforms Position	Optimum
Shape of Print Aperture	Circular
Pin Shape	Circular
(Hole - Pin Diameter)	30 mils

Table 3: Default Constants

The following problem statements were designed and investigated in the study.

- 2.2.1 Tin-lead versus Lead-free Assembly Process (Problem Statement 1): In this study, 30 boards were assembled using lead-free process and 20 boards were assembled using tin-lead assembly process. The objective was to compare tin-lead and lead-free PiP assembly process and determine if there is any difference in the properties.
- 2.2.2 Effect of Annular Ring Pad Geometry (Problem Statement 2): The goal of the design was to determine if there is any difference between square and circular designs for annular ring pad, with respect to PiP process. To study this problem, each staple pin was designed with circular annular ring on one end and square annular ring on the other end of the pin, as shown in Figure 3.1.
- 2.2.3 Effect of Solder Mask Type (Problem Statement 3): The type of solder mask coated on the PCB could have a significant impact on the PiP process, as it could influence the pull back behavior of solder paste and preforms towards the barrel. In this study, 50% of the test vehicle PCBs were coated with glossy solder mask type and the other 50% of the TV boards were coated with matte solder mask type and assembled using PiP process with solder preforms.
- 2.2.4 Overprinting (Problem Statement 4): In PiP process, the solder paste needs to be often overprinted around the annular ring pad to provide additional solder volume and real estate for placing solder preforms. The size of the overprint is determined by the Required Solder Volume (RSV) and space available around the annular ring pad. In this study, overprint stencil apertures ranging from 150 mils X 150 mils to 250 mils X 250 mils were designed as shown in Figure 3.1. Overprint apertures larger than 250 mils X 250 mils were not considered in this study, as it's impractical due to real estate constraints on the board. A 0805 preform was also placed at the corner of the solder paste aperture. The goal of the design was to determine if the solder paste and the 0805 preform pull back into the barrel for all the cases.
- 2.2.5 Overprinting with Offset (Problem Statement 5): For fine pitch components, overprinting may not be possible in one direction due to real estate constraints and also due to limitations from PTH component pitch. For those cases, it would be prudent to overprint by offsetting the print in the direction where there is available real estate. In this study, overprint stencil apertures ranging from 150 mils X 150 mils to 250 mils X 250 mils were designed with an offset as shown in Figure 3.2. A 0805 preform was also placed at the corner of the solder paste aperture. The goal of the design was to determine if the solder paste and the preform pull back into the barrel for all the cases.
- 2.2.6 Types of Preforms (Problem Statement 6): There are several sizes and types of preforms available in the market. The type of preform to be used for a particular component depends on the Required Solder Volume (RSV) and the standoff available under the component. In this study, several combinations of preforms were placed to achieve the target holefill and study the preform behavior as shown in Figure 3.3. The goal is to determine:
- Would all sizes and types of preform pull back inside the barrel during reflow process?
  - Would placing several preforms in close proximity create issues like solder balls or bridging?
- 2.2.7 Limitation of Solder Preform Placement (Problem Statement 7): In some instances, the preforms couldn't be placed completely within the solder paste. So in this design, a 0805 preforms was placed at different locations within the solder paste, as shown in Figure 3.4. The goal of the design was to determine if the 0805 preform pulls back inside the barrel for all cases.

- 2.2.8 Pin to Hole Clearance (Problem Statement 8): One of the key design parameter of PiP process, is determining the optimum Pin to Hole clearance that would provide the best holefill. The benefit of using smaller pin to hole ratio is that they require less solder volume to fill the barrel. However, the disadvantage is that solder may find it difficult to flow through the small clearance, resulting in poor holefill. It's also difficult to place the component, especially by auto insertion. If the Pin to Hole clearance is larger than the optimum window, there could be possibility of voids and gaps in the barrel, due to weakening of surface tension between barrel walls and solder paste. In this study, Pin to Hole clearance from Pin + 10 mils to Pin + 50 mils were examined, as shown in Figure 3.5.
- 2.2.9 Effect of Pin Protrusion (Problem Statement 9): When the PTH component is placed inside the barrel, the pin would push some amount of solder paste outside the barrel. The amount of paste displaced is believed to be proportional to the length of pin protrusion. The IPC requirement for minimum protrusion for PTH components is 60 mils. In this study, pin protrusion varying from 0 mils (no protrusion) to 100 mils were examined as shown in Figure 3.6. The goal was to determine the minimum and maximum and pin protrusion for PiP process. All the pins used in the study were rounded, as blunt pins used in the previous phase of the study were shown to push a large amount of solder paste outside the barrel.
- 2.2.10 Ratio of Preforms Volume/ Solder Paste Volume: The solder preform provides additional solder volume but the standard version of preforms does not contain any flux. Since, the preforms are solid metal, only a small amount of metal oxide is present, on the surface of the preform. The flux necessary for making a good solder joint comes from the solder paste. In a scenario where a lot of preforms are added such that the Preforms Volume/ Solder Paste Volume ratio becomes very high, there could be inadequate flux to reflow the solder joint completely. In this study, the maximum Preform Volume / Solder Paste volume was determined by using the design shown in Figure 3.7. The stencil apertures were blocked, and the volume to fill the hole was provided largely by solder preforms. The PCBs were reflowed in a Nitrogen atmosphere.

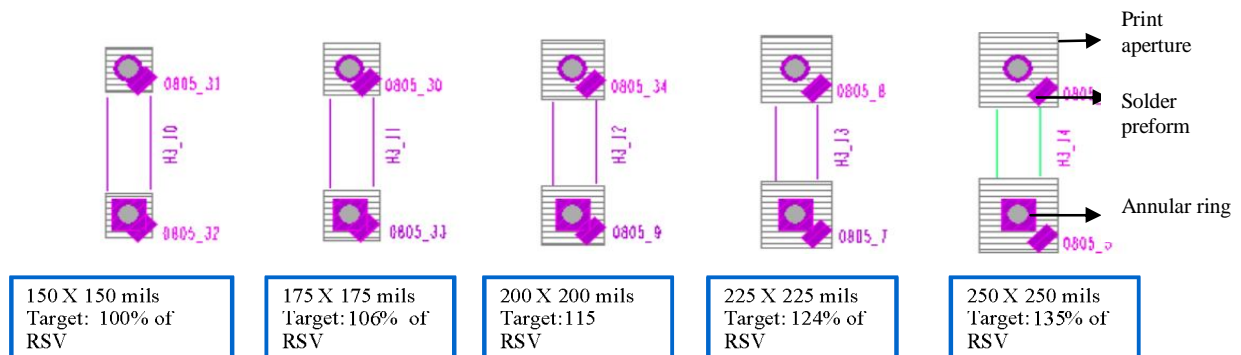

Figure 3.1: Overprinting around annular ring with 0805 preform at corner. The worst case scenario is 250 X 250 mils. A 2 pin staple was used to study the problem. The pin has square pad on one end and circular pad on other end

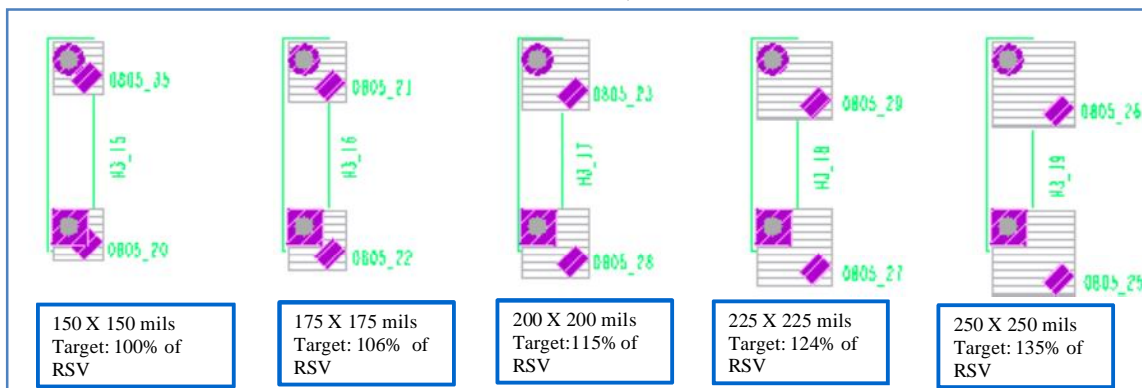

Figure 3.2: Overprinting with offset around annular ring with 0805 preform at corner. The worst case scenario is 250 X 250 mils

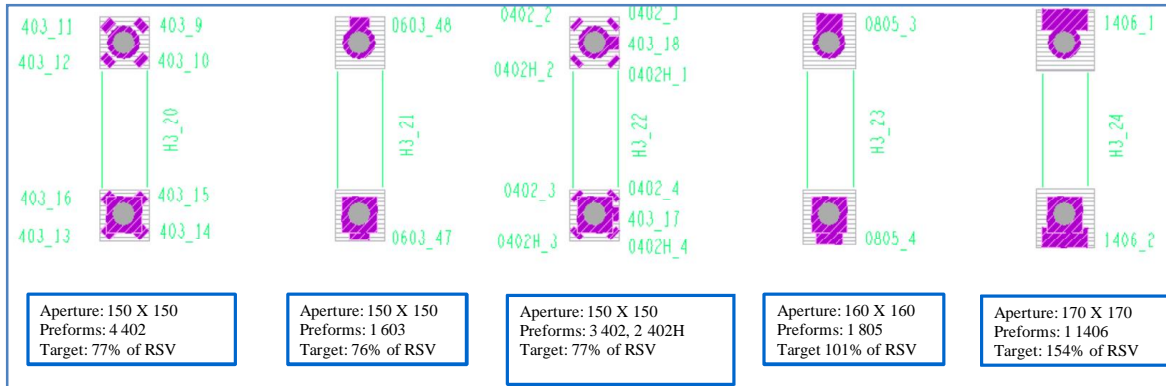

Figure 3.3: Different Combination of Preforms to achieve target holefill%

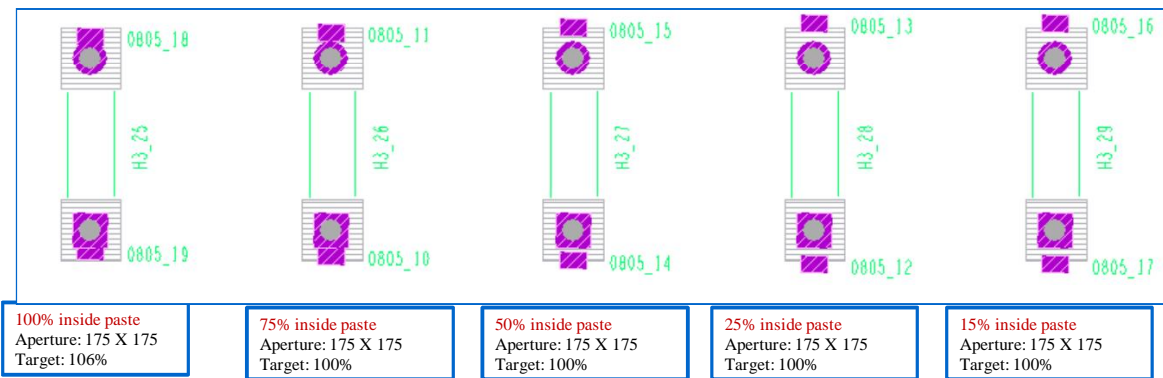

Figure 3.4: Limitation of Placing Preforms within the solder pastes

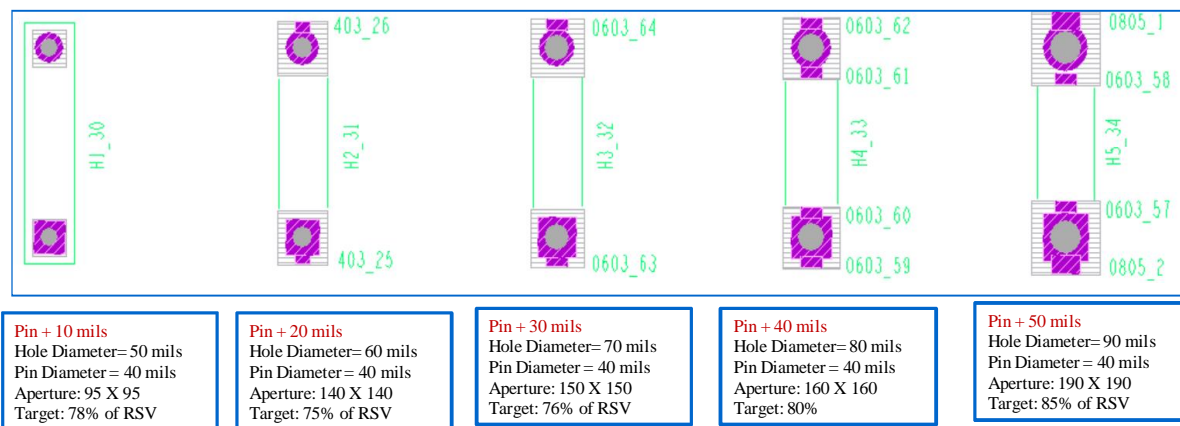

Figure 3.5: Effect of Pin to Hole Clearances

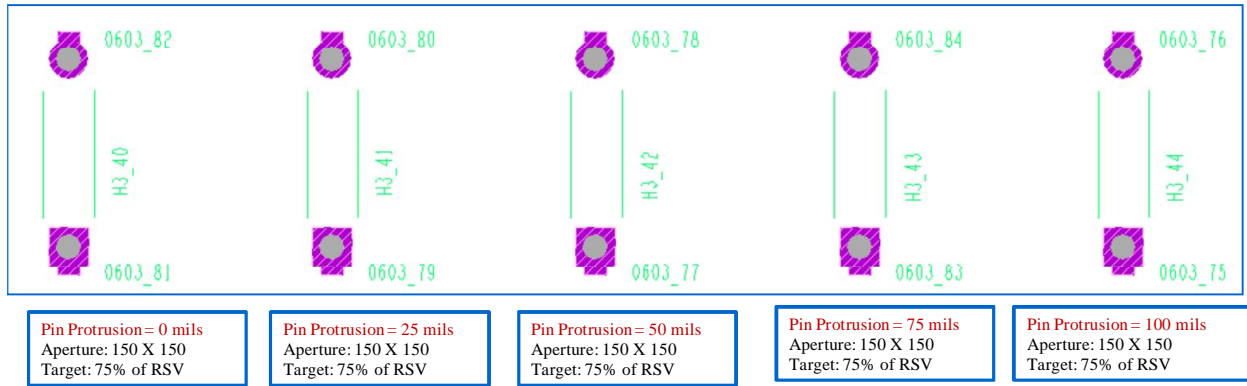

Figure 3.6: Effect of Pin Protrusion Length

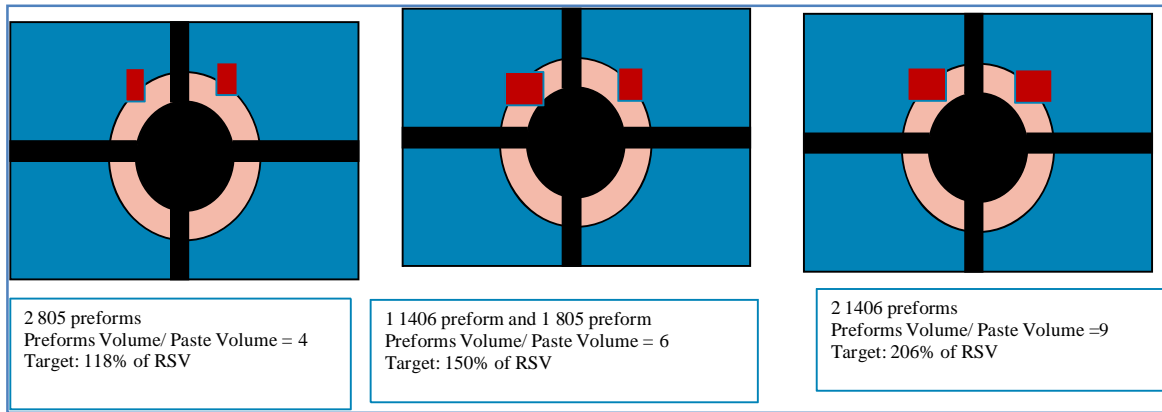

Figure 3.7: Effect of adding several preforms with a blocked stencil hole

### 2.3 TEST VEHICLE AND COMPONENTS

A very challenging Test Vehicle (TV) was designed to study all the problem statements listed in Table 2. The details of the test vehicle are listed in Table 4. All the vias of the TV were connected to all the internal layers of the board, to represent the most challenging scenario.

Details of Test Vehicle	Value
Board Dimensions	8 inches X 8 inches
PCB Surface Finish	Copper OSP
Laminate Material	370 HR
Number of Layers	12
Thickness	130 mils

Table 4: Test Vehicle Details

After designing the test vehicle, the components that would be populated on the TV were selected. The list of components that were selected, are shown in Table 5. Tin coated staple pins were used to study problem statements 1 to 10, listed in Table 2, as they are inexpensive, simple to inspect and analyze. In addition to staple pins, actual PTH components of various types, were populated on the Test Vehicle. All the components selected for this study were designed for PiP process and could withstand Pb-Free reflow temperature. The fully assembled TV is shown in Figure 4.



Ref Des	Description	Total Number of Pins	Pitch(mils)	Pin Length(mils)	Standoff (mils)
A1	Quarter Power Brick	7	300, 150	20	20
A2	MAGJACK	16	80, 100	20	16
A3	RJ45	8	100,100	-2	16
A4, A5	Header	16	2.54	-50	16
A6, A7	Header	16	2	-50	12
HX_10 to HX_39	Tin coated staple Pins	2	300	Staple pins are designed to have different protrusion	Not applicable

Table 5: Components used in Test Vehicle

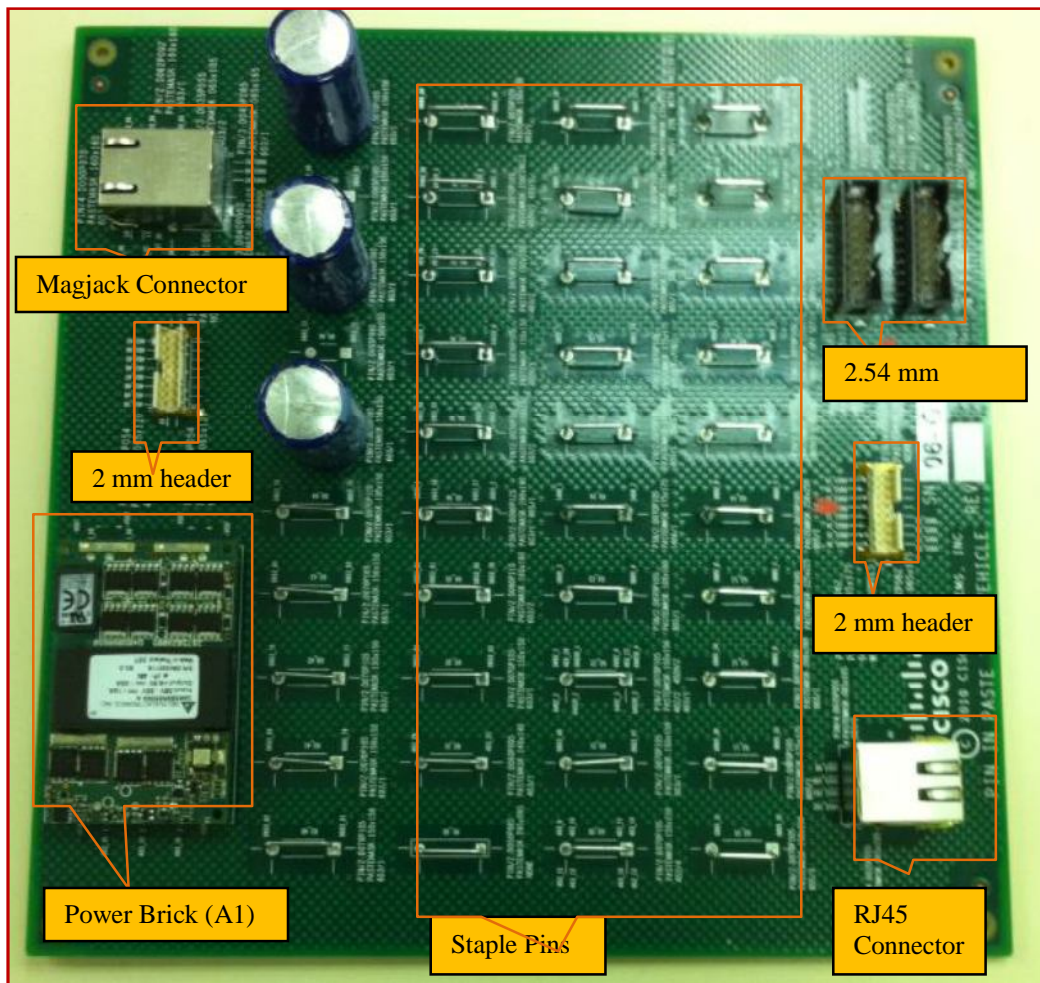

Figure 4: Assembled Test Vehicle and Components

2.4 TEST VEHICLE ASSEMBLY

A total of 50 boards were assembled according to the matrix shown in Table 6.

Boards	SnPb/ Pb-Free	Type of Solder Mask
I to 10	SnPb	Glossy
11 to 20	SnPb	Matte
21 to 35	Pb-Free	Glossy
35 to 50	Pb-Free	Matte

Table 6: Assembly Test Matrix

Solder paste printing: An electroformed stencil of thickness 5 mils was used for stencil printing. The aperture dimensions for the stencil were calculated based on the equations discussed in section 2.1. The solder paste volume was measured using a 3D solder paste inspection equipment. The printing parameters were optimized to provide the maximum theoretical solder paste volume.

Placement of preforms: The next step following solder paste printing, was to place the solder preforms on the top of the printed solder paste. The solder preform combination and its locations were determined by the logic discussed in section 2.1 and included in the Gerber file. The solder preforms available in tape and reel format were placed by a chip shooter pick and placement equipment.

Component placement: All the PTH components listed in Table 5 were placed manually with paying special attention not to disturb the solder preforms and solder paste. The staple pins were mounted on an aluminum cylindrical rod which acts as the support for staple pins, during the reflow process. The staple pin mounts were removed after the reflow process. It should be noted, that automatic insertion technology is available in the industry that could place the PTH components accurately at a very fast rate.

Reflow process: The boards were reflowed in a Nitrogen atmosphere using the recommended reflow profiles from the solder paste supplier. It should be noted that this study used Nitrogen, but it is not required for the functionality of holefill using solder paste and preforms

Inspection: After assembly, all the boards were visually inspected for solder balls, bridges, holefill, top fillet and bottom fillet. The presence of a big solder ball indicates that the particular preform was not pulled inside barrel during the reflow process. The exact amount of holefill% was measured quantitatively using a 5DX equipment. Figure 5 illustrates a sample calculation using a 5DX equipment, calculated based on the grey scale level measurements (GL1-GL10), collected from 10 slides.

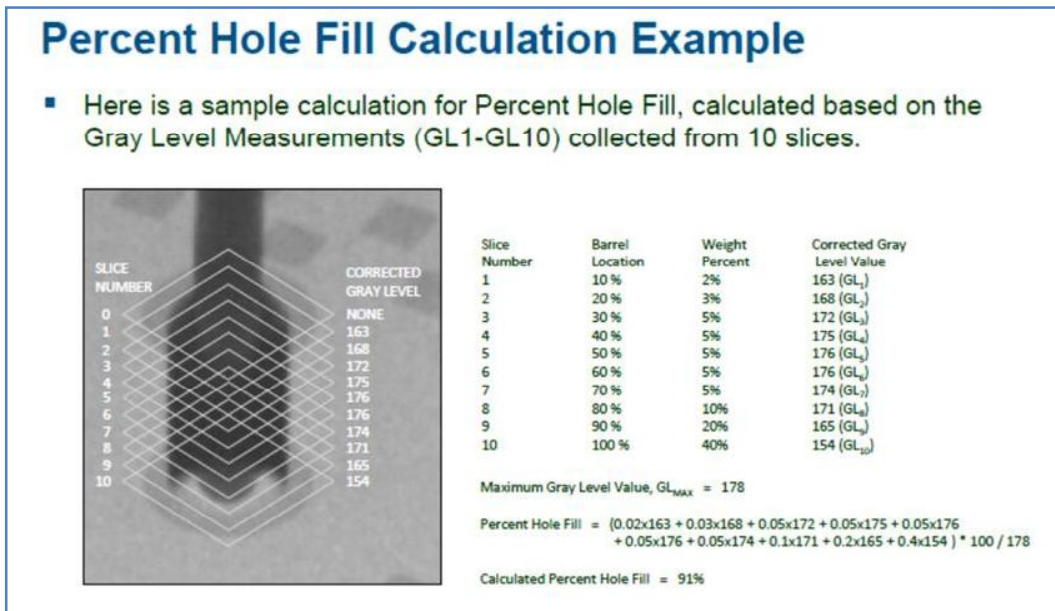

Figure 5: Sample Holefill Calculation using 5DX Equipment

### 3 RESULTS AND DISCUSSION

In this section, the results for each problem statement listed in Table 2 is individually presented and discussed. First the results from the visual inspection by microscope are presented. Then the data collected from 5DX inspection was analyzed using a statistical software and presented as easily understandable graphs. Finally, observation and inferences from the graphs are discussed in detail.

- 3.1 Tin-lead versus lead-free assembly: The visual inspection showed no difference in holefill% between tin-lead and lead-free assembly. The results from the 5DX inspection was plotted in a box plot graph and shown in Figure 6.1. A statistical paired t-test was conducted on the data and the result showed no significant difference between tin-lead and lead-free assembly. Since there was no significant difference, tin-lead and lead-free data were combined for analysis of other variables.
- 3.2 Annular ring geometry: The visual inspection showed no difference between square and circular annular ring pads. There were no anomalies such as solder balling and bridging. The results from 5DX inspection was plotted in graph and shown in Figure 6.2. A statistical paired t-test was conducted on the data and the result showed no significant difference in holefill% between square and circular annular ring pads. Since there was no significant difference, square and circular pad data were combined for further analysis.
- 3.3 Effect of solder mask type on PCB: The visual inspection showed no difference between glossy and matte solder masks. The results of the 5DX inspection were plotted in a box plot and are shown in Figure 6.3. A statistical t-test was conducted on the data and the result showed no significant difference in holefill between glossy and matte solder masks. Since there is no significant difference, glossy and matte solder mask data were combined for further analysis.
- 3.4 Overprinting of solder paste: The visual inspection by 10X microscope showed no anomalies for all the cases shown in Figure 3.1. The holefill% was close to 100% and there was presence of good top and bottom fillet formation around the pad. The results from 5DX inspection was plotted in a box plot graph and shown in Figure 6.4. The graph shows no anomalies, even for the worst case overprinting of 250 mils X 250 mils. This data demonstrates, that both the solder paste and 0805 preform pulled back inside the barrel, even for the worst case scenario, where the solder paste tip is as far as 100 mils from annular ring pad tip. The sequence of the entire reflow process was simulated using BGA rework equipment and was captured using a video camera. The video demonstrated that after the peak reflow temperature, the solder paste melted pulling the 0805 preform along with it towards the inside of the barrel. An interesting observation was that the solder preform melted a few seconds after the solder paste melted and was drawn toward the barrel as a block, melted completely, then filled the barrel along with the solder paste metal.
- 3.5 Overprinting of solder paste with offset: The results were similar to that of the previous case (section 3.4) without offset. The visual inspection by 10X microscope showed no anomalies for all the cases shown in Figure 3.2. The holefill% was close to 100% and there was presence of top and bottom fillet formation. The results of the 5DX inspection was plotted in a box plot graph and shown in Figure 6.5. This data implies that both the solder paste and 0805 preform pulled back inside the barrel, even for the worst case scenario of overprinting with an offset of 250 mils X 250 mils, where the solder paste tip was as far as 200 mils from the annular ring tip.
- 3.6 Types of preforms: The visual inspection by 10X microscope showed no anomalies for all the cases shown in Figure 3.3. The result showed, all sizes of preforms pulled back inside the barrel leaving no solder balls. It also demonstrates, several preforms (up to 5 preforms in this case) can be placed in close proximity to each other without any issues. The holefill% for all the samples was determined using 5DX equipment and the result was plotted in a box plot graph and shown in Figure 6.6. From the graph it could be inferred that the holefill% was close to target holefill%, implying a predictable process. A graph was also plotted to compare the holefill% by the addition of different sizes preforms for the following example case: Stencil thickness = 5 mils, solder paste print = 150 mils X 150 mils, hole diameter = 70 mils, pin diameter= 40 mils, board thickness = 130 mils. The graph is shown in Figure 6.6.
- 3.7 Limitation of placing solder preform: The visual inspection showed no anomalies for all cases shown in Figure 3.4. The 5DX result was plotted in a graph and shown in Figure 6.7. The data from the graph demonstrates that solder preform pulled back inside the barrel even for the worst case scenario, where only 15% of the solder preform body was touching the solder paste.

- 3.8 Effect of pin to hole clearance: The visual inspection showed no anomalies for all the cases shown in Figure 3.5. The amount of solder paste deposited inside the barrel during printing, was measured using a 5DX equipment. The data showed, that the amount of solder pastes is proportional to the hole diameter and follows the following linear regression equation.

$$\text{Length of solder paste pushed inside barrel during printing} = 21.4 + 0.6 X \text{ Hole Diameter}[7]$$

The holefill% was also calculated for all pin to hole clearances and was plotted in a graph shown in Figure 6.8. From the graph, it could be inferred that the actual holefill% was close to the target holefill% for all the cases. Although Pin + 10 mils had no anomalies, it's not preferred, due to the very small clearance which would make it difficult to place the component. Pin + 20 mils, Pin + 30 mils and Pin+ 40 mils produced the best results and were recommended as the preferred 'pin to hole' clearances. Although, Pin + 50 work and had no solder balls issues, they are not preferred as they would require more solder volume to fill the barrel and the risk of voids inside the barrel. It should be noted that as the pin count of the connector component increases, a larger hole to pin ratio is preferred to assist with ease of insertion into the board.

- 3.9 Effect of pin protrusion: The visual inspection showed no anomalies for all the cases shown in Figure 3.6. The barrels were inspected by x-ray after placement the pins and before the reflow process. The x-ray images revealed some amount of solder paste being pushed outside the barrel for longer pin protrusion (75 and 100 mils). Therefore, shorter pin protrusions are recommended. For PiP process, it was observed the shorter the pin, the better the holefill%. So, typically no pin protrusion is required for PiP process. However, a minimum pin protrusion of 5 mils is preferred for inspecting missing pins. In this study, blunt pins were also shown to push a large amount of solder paste outside the hole, whereas rounded and tapered pins didn't push any solder paste outside the barrel for modest pin protrusion amounts.
- 3.10 Ratio of Preforms Volume/ Solder Paste Volume: The visual inspection revealed no anomalies even for Preform Volume/ Solder Paste Volume ratio of 9. However, this ratio holds true only if the soldering is done in a Nitrogen atmosphere.
- 3.11 Soldering of Pin Through Hole Components: All the Pin Through Hole (PTH) components were successfully soldered using the PiP process with combination of solder preforms. There were some important observations while soldering these components.

**Power Bricks:** This type of component is a good candidate to be soldered using PiP process with combination of solder preforms. The power brick usually have a shoulder which acts as an integrated standoff as shown in Figure 7.1. The pins are usually chamfered on two sides. The purpose of the chamfer for wave soldering is to provide a vent for outgassing during the reflow process. The chamfers are also a requirement for PiP process with combination of solder preforms. Without the chamfers, the hole will be sealed and there would be no path for preforms to flow inside the barrel. The component was soldered successfully by using the solder paste and preform configuration shown in Figure 7.2. Barrel fill of 100% was obtained using this design.

**Headers:** Two types of PTH headers with 2.54 mm and 2 mm pitch were soldered successfully in this study. The solder paste was offset, to avoid bridging. The main requirement for the headers, is that it should have adequate standoff height underneath the component body for the flow of preforms. The minimum standoff is given by the following equation:

$$\text{Minimum Standoff Required} = \text{Stencil Thickness} + \text{Preform Height} + \text{Tolerance}[8]$$

For instance, for a stencil thickness of 5 mils, tolerance of 3 mils and for placing a 402 preform (Height= 20 mils), the minimum standoff required the standoff height, a low profile preform with smaller height may be required.

It was also noted that the location of the connector standoff tabs should be noted when designing stencils to print solder paste and to locate solder preforms in that paste. Offset printing of the solder paste may be required to avoid the area of the board where the standoff will rest once the component is placed.

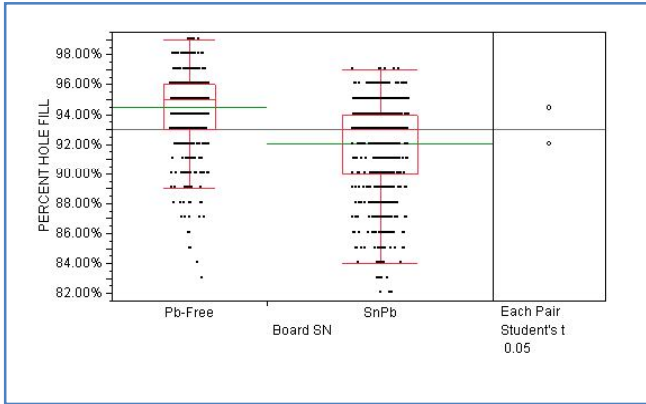

Figure 6.1: Box plot of holefill% comparing tin-lead and lead-free assembly. Paired t-test shows no significant difference.

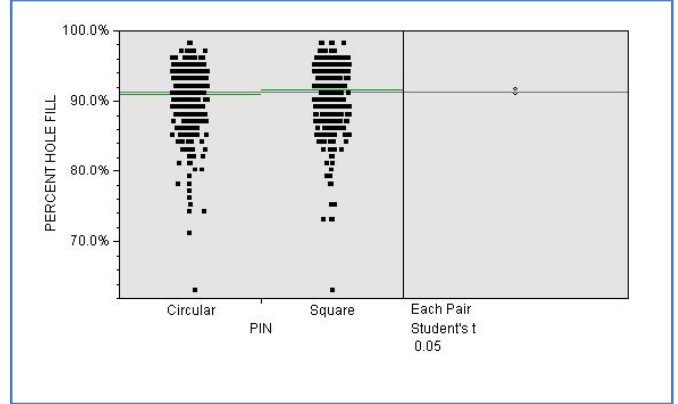

Figure 6.2: Box plot of holefill% comparing circular and square annular ring pads. Paired t-test shows no significant difference

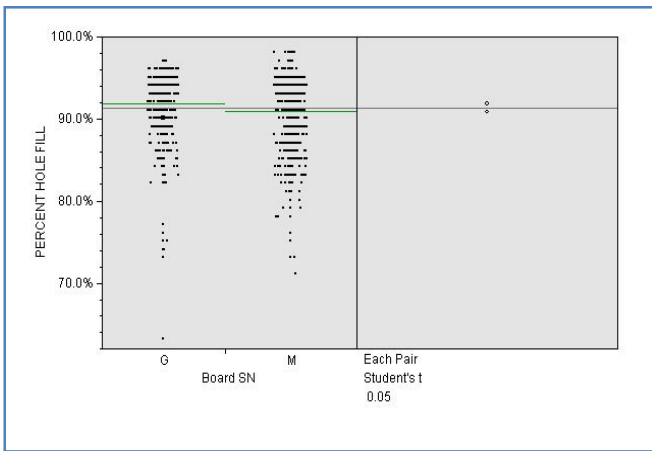

Figure 6.3: Box plot of holefill% comparing glossy and matte solder masks. Paired t-test shows no significant difference.

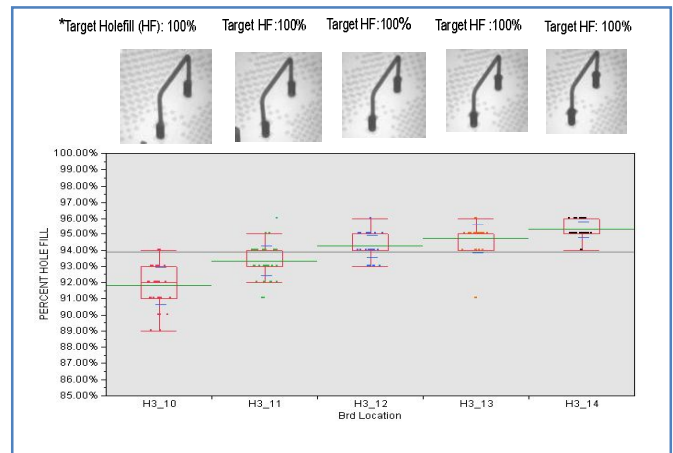

Figure 6.4: Box plot of holefill% for solder paste overprinting. A sample x-ray image and target holefill% for each case, are shown at top of the box plot.

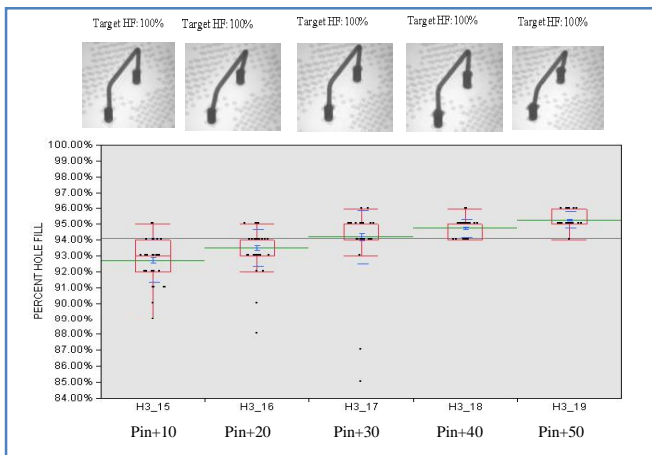

Figure 6.5: Box plot of holefill% for solder paste overprinting with offset. A sample x-ray image and target holefill% for each case, are shown at top of the box plot.

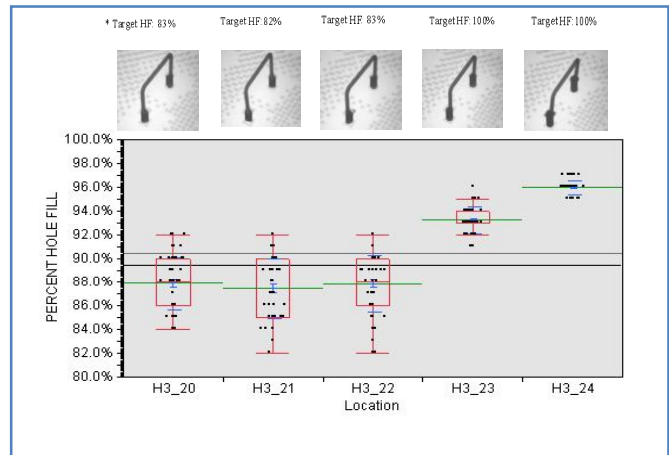

Figure 6.6: Box plot of holefill% for different combination of solder preforms. A sample x-ray image and target holefill% for each case, are shown at top of the box plot.

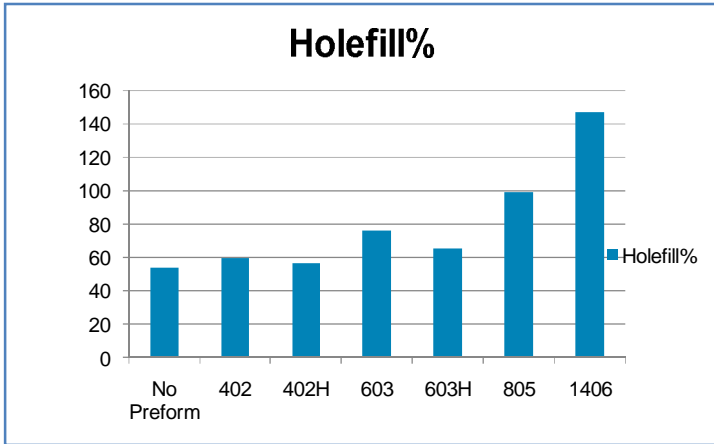

Figure 6.7: Graph showing additional holefill% provided by different sizes of preforms with fixed amount of solder paste, for an example case.

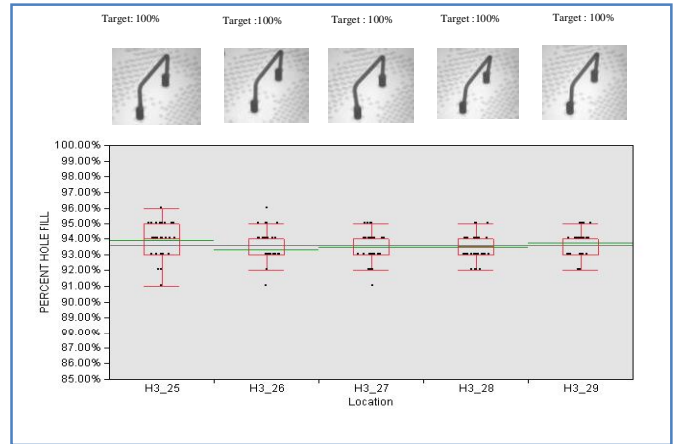

Figure 6.8: Box plot of holefill% for solder preforms placed at different locations within the solder paste.

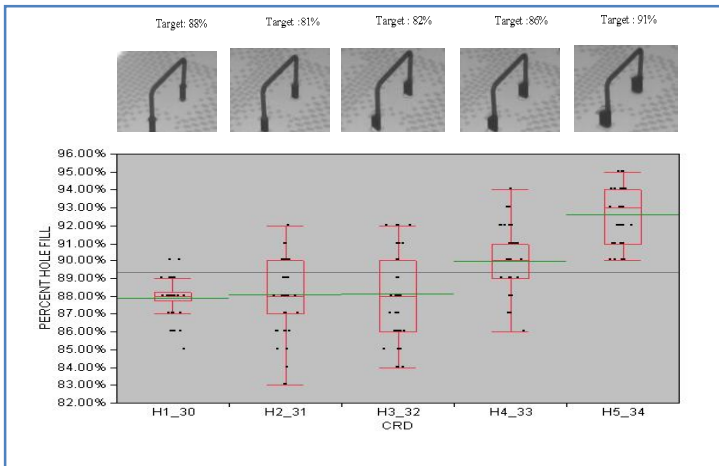

Figure 6.9: Box plot showing holefill% for different pin to hole clearances

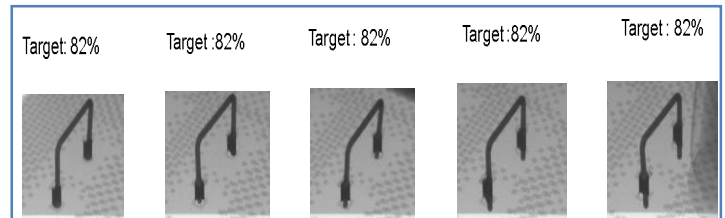

Figure 6.5: X-ray images of holefill% for various pin protrusion length.

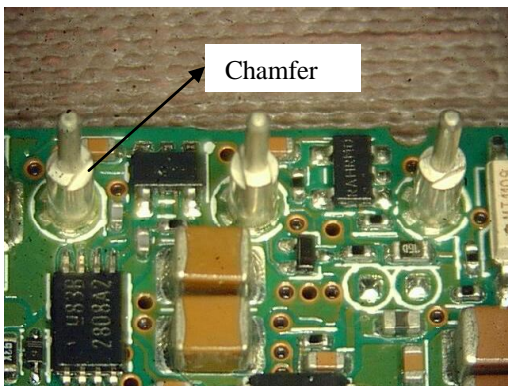

Figure 7.1: Chamfer in power brick necessary to provide a gap for solder to flow inside the barrel.

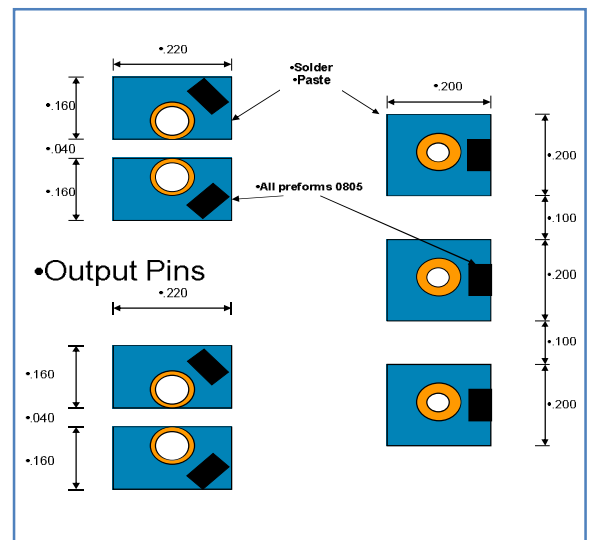

Figure 7.2: Preform configuration for 7 pin power bricks. This will give 100% holefill for hole size of pin+30 mils.

#### 4 CONCLUSIONS AND SUMMARY

The PiP process with combination of solder preforms was shown as an attractive option for soldering PTH components, as it provides several benefits over the conventional wave soldering process. However, there are some challenges that need to be addressed before it could be implemented in a high volume production. The primary challenge would be designing the PTH component for PiP process. The component suppliers must redesign the component to withstand SMT reflow temperature and provide adequate standoff underneath the component, for placement of solder preforms. The original equipment manufacturers need to lead the effort and drive the component suppliers to redesign the PTH components. In terms of assembly, the following are key observations and necessary guidelines to be followed while implementing PiP process with combination of solder preforms.

- There was no significant difference between tin-lead and lead-free assembly.
- There was no significant difference between glossy and matte solder mask types.
- There was no significant difference between square and circular annular ring pads.
- Solder paste could be overprinted around an annular ring to increase solder volume and to provide real estate for placing preforms. Even for the worst case scenario of overprint 250 mils X 250 mils, both solder paste and preform pulled back inside the barrel.
- For fine pitch components, overprinting may not be possible in one direction due to real estate constraints. For those cases, it might be useful to overprint by offsetting. In this study, overprints of 250 mils X 250 mils, were offset in one direction and was soldered without any issues. It was also observed in this study, as long as there is an air gap of 10 mils present between 2 paste apertures, there will not be bridging for fine pitch components.
- It was observed in the study, that preform could be placed anywhere within the solder paste, provided a minimum of 15% of the preform body is lying inside the solder paste.
- It was observed in the study that good solder joint formation could occur even if preform volume (preforms has no flux) was as high as 9 times that of solder paste volume. However this is valid only if the reflow is performed in a Nitrogen atmosphere.
- Pin to hole clearances of Pin + 20 mils to Pin +40 mils produced excellent results.
- Longer pin protrusion and blunt pin ends pushed large amount of solder paste outside the barrel. So, shorter pin protrusion (less than 20 mils) is recommended from the study.
- If the use of PTH components with long pins is required, blocking or partially blocking the hole with the stencil is an effective method for delivering a predictable amount of solder without volume loss due to excess pin protrusion.
- PTH components such as power bricks, fine pitch headers and RJ45 connectors were soldered successfully in this study. The important requirement for these connectors, is adequate standoff height; standoff has to be higher than the preform height that is being deployed.

#### Future work:

- Cross-sections for the PTH components covering all the factors considered in the DOE are currently underway. Hole fill results from these cross-section will be further correlated with the results from visual inspection and 5DX X-Ray analysis.
- For a comprehensive PiP process development, design guidelines for the rework of PTH components, assembled through this new process will also be developed.

#### Acknowledgements:

The authors would like to thank Bill Fabry for his great passion towards implementing PiP technology at Cisco and invaluable guidance to the project. We like to thank Steven Perng, Tim Dick, Mike Anvari, Chuan Xia, May Yan and Reggie Higdon from Assembly Sciences Technology (AST) Team, Cisco Systems for their valuable inputs and feedbacks to the study. We would like to thank Ken Hubbard and Damon Northrop from Cisco for their support and ideas. The authors would also like to specially thank Quyen Chu, Mike Lapitan and Josh Salon from Jabil AMT group for their assembly expertise and working diligently (14 hours a day) to complete the assembly of Test Vehicles. We would like to appreciate the support of Foxconn San Jose team (David Yee, Maosen Cheng, Chu Lin, Joseph Lee) for their great contribution during first phase of the study. We would like to appreciate the support of component suppliers: Brian Motooka (FCI Headers), Bill Kottmeir (Samtec), Taylor Tsai (Delta Electronics Power Bricks) and James Hvidt (Belfuse RJ45) for participating and providing samples to the study.

#### References:

1. Zarrow, P., "Reflow Soldering of Through-Hole Components", Journal of Surface Mount Technology Association International, October, 1999.
2. Pefennich, P., et al., "Board Design and Process Optimization for Paste-In Hole using Lead-Free Solder", Proceedings of Surface Mount Technology Association International (SMTAi), September, 2004.
3. Grano, F., et al., "Intrusive reflow using a lead-Association International (SMTAi), September, 2006.